

RANGE COMPOSITION

EVO700: range comprised of over 100 models designed to guarantee the highest level of performance, reliability, energy saving, safety standards and ergonomic operation. These concepts are reflected throughout the line in its modularity, construction and numerous configurations. Thanks to its advance technology and premium performance, the EVO700 is a perfect solution for institutions with a limited footprint as well as restaurants needing to obtain the most from the kitchen space. The models detailed in this sheet are 15 litres fryers in gas version with one or two wells.



EVO700

GAS FRYERS - 15 LT ZANUSSI PROFESSIONAL

FUNCTIONAL AND CONSTRUCTION FEATURES

- ◆ Stainless steel burners with optimized combustion, flame failure device and protected pilot light.
- ◆ The external burners guarantee a long oil life thanks to the indirect heating system and uniform distribution of heat.
- ◆ Thermostatic regulation of oil temperature from 105°C to 185°C.
- ◆ All models have right-angled side edges to allow flush-fitting joints between units, eliminating gaps and possible dirt traps.
- ◆ Overheat safety thermostat.
- ◆ Deep drawn V-Shaped well with rounded corners and external burners for safe and easy cleaning.
- ◆ The V-Shaped well is made from two pieces of pressed stainless steel that are seamlessly welded together for maximum hygiene, safety and reliability.
- ◆ The special design of the control knobs and bezels guarantees against water infiltration.
- ◆ One piece pressed worktop in 1,5mm stainless steel with smooth, rounded corners.
- ◆ Front panel in stainless steel with Scotch Brite finish.
- ◆ Feet in stainless steel adjustable in height 50mm.
- ◆ Oil drainage via a tap into a drainage

container positioned under the well thus simplifying the consumed oil management and guaranteeing the operator safety.

- ◆ IPX4 water protection.
- ◆ Main connections are accessible from below the base of the unit.
- ◆ Access to all components from the front
- ◆ All top models provided with service duct to facilitate installation.
- ◆ Appliances are supplied for use with

natural gas or LPG. Conversion jets supplied as standard.

TECHNICAL DATA		
CHARACTERISTICS	MODELS	
	Z7FRGD1GF0 372070	Z7FRGH2GF0 372071
Power supply	Gas	Gas
External dimensions - mm		
width	400	800
depth	700	700
height	850	850
height adjustment	50	50
N° of wells	1	2
Usable well dimensions - mm		
width	240	240
depth	380	380
height	505	505
Temperature limiter	●	●
Thermostat range (min-max) - °C	105, 185	105, 185
Maximum Well Capacity -lt	13, 15	13, 15
Power - kW		
gas	14	28
Net weight - kg.	55	85
INCLUDED ACCESSORIES		
BASKET FOR 14/15 LT FRYERS	1	2
DOOR FOR OPEN BASE CUPBOARD-ZANUSSI	1	2

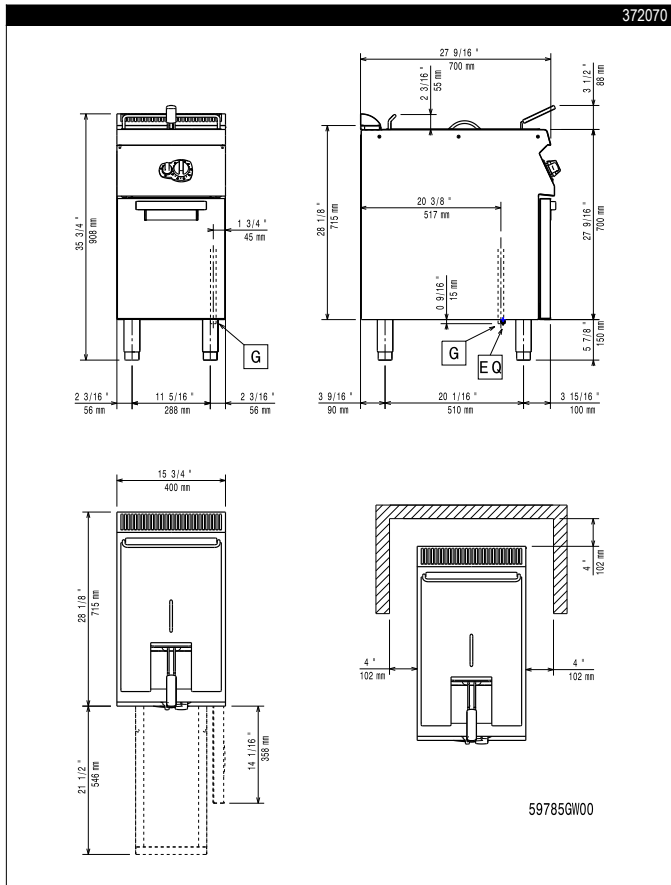

59785GW00

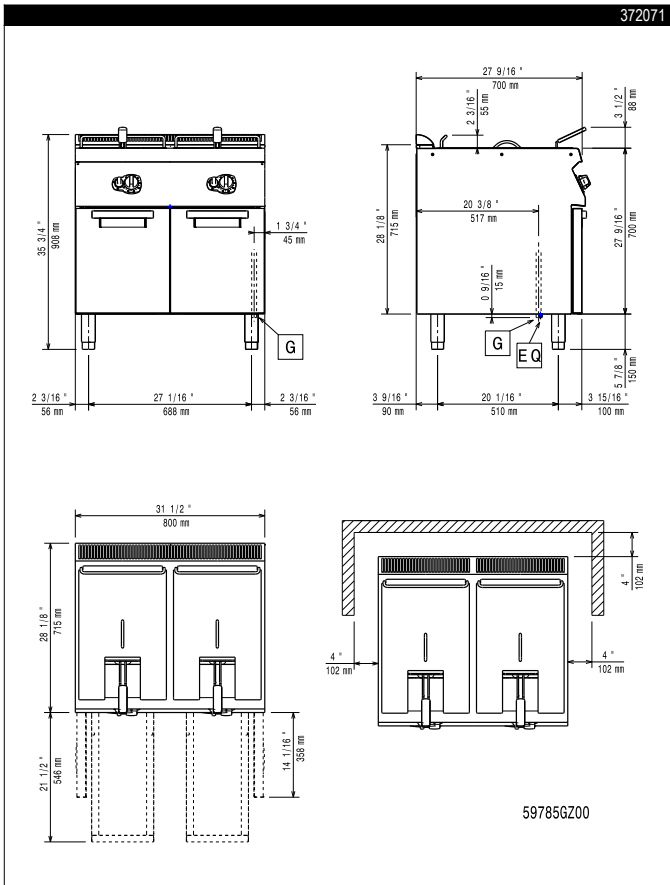

59785GZ00

LEGEND

G - Gas connection

Z7FRGD1GF0
372070

1/2"

Z7FRGH2GF0
372071

1/2"

OPTIONAL ACCESSORIES

ACCESSORIES

MODELS

Z7FRGD1GF0
372070

Z7FRGH2GF0
372071

2 1/2 BASKETS FOR 14/15 LT FRYERS	921692	921692
2 SIDE COVERING PANELS H=700-D=700-Z/OEM	206319	206319
2 SIDE KICKING STRIPS - 700 LINE	206249	206249
2 SIDE KICKING STRIPS-CONCRETE INST-700	206265	206265
4 FEET FOR CONCRETE INSTALLATION	206210	206210
BASKET FOR 14/15 LT FRYERS	921691	921691
CHIMNEY COVER 400MM OPEN	206284	
CHIMNEY UPSTAND 400MM	206303	
CHIMNEY UPSTAND 800MM		206304
DEFLECTOR FOR FLOURED PRODUCTS-15L FRYER	921696	921696
DOOR FOR OPEN BASE CUPBOARD-ZANUSSI	206342	206342
DRAUGHT DIVERTER WITH 120 MM DIAMETER	206126	
DRAUGHT DIVERTER WITH 150 MM DIAMETER		206132
FILTER FOR FRYER OIL COLLECTION BASIN	921693	921693
FLANGED FEET KIT	206136	206136
FLUE CONDENSER FOR 1 MODULE DIAM.150MM		206246
FLUE CONDENSER FOR 1/2 MOD. DIAM.120MM	206310	
FRONT.KICK.STRIP F.CONCRETE INST.1000 MM	206150	206150
FRONT.KICK.STRIP F.CONCRETE INST.1200 MM	206151	206151
FRONT.KICK.STRIP F.CONCRETE INST.1600 MM	206152	206152
FRONT.KICK.STRIP F.CONCRETE INST.200 MM	206146	206146
FRONT.KICK.STRIP F.CONCRETE INST.400 MM	206147	206147
FRONT.KICK.STRIP F.CONCRETE INST.800 MM	206148	206148
FRONTAL HANDRAIL 1200 MM	206191	206191
FRONTAL HANDRAIL 1600 MM	206192	206192
FRONTAL HANDRAIL 400 MM	206166	
FRONTAL HANDRAIL 800 MM	206167	206167
FRONTAL KICKING STRIP 1000 MM	206177	206177
FRONTAL KICKING STRIP 1200 MM	206178	206178
FRONTAL KICKING STRIP 1600 MM	206179	206179
FRONTAL KICKING STRIP 200 MM	206174	206174
FRONTAL KICKING STRIP 400 MM	206175	206175
FRONTAL KICKING STRIP 800 MM	206176	206176
LARGE HANDRAIL(PORTIONING SHELF)400 MM	206185	206185
LARGE HANDRAIL(PORTIONING SHELF)800 MM	206186	206186
MATCHING RING FOR FLUE CONDENSER 150DIAM		206133
MATCHING RING-FLUE CONDENSER 120-130DIAM	206127	
PRESSURE REGULATOR FOR GAS UNITS	927225	927225
SEDIMENT TRAY FOR 15 LT FRYER	206235	206235
SIDE HANDRAIL-RIGHT/LEFT HAND-700 LINE	206240	206240
UNCLOGGING ROD F.15LT FRYER DRAIN.PIPE	921695	921695



www.zanussiprofessional.com