



Produktnavn

2-armet universalaftrækker med selvcentrerende aftrækningskroge

Til aftrækning af lejer, tandhjul, skiver etc.

Varenr. 44-1

Serie 44

EAN 4021176016028



	Teknisk egenskab	Metrisk	Tomme
	Spændvidde udvendig	12 - 100 mm	1/2 - 3 7/8 inch
	Spænddybde	100 mm	3 7/8 inch
	Udvendig sekskant	13 mm	
max.	Maksimal tilladt belastning	3 t	3 US t
	Maks. drejningsmoment	50 Nm	6.5 ft lb
	Vægt	0.525 kg	
	Rum nedenunder	7 mm	1/4 inch
	Rum ved siden af	20 mm	3/4 inch
	Antal kroge	2	2



Teknologier



SWITCH

Optimal spindeltilpasning til akslen gennem spindelspidser på to sider.

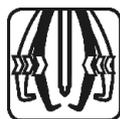

AUTOGRIP

Aftrækkerkrogene spændes og centrerer automatisk.



Reservedel

Varenr.	Produkt navn
44-1-T	Travers
44-1-100-P	2 aftrækningskroge (par)
44-1-206	Traversinderbøsning med spindel
612130	Mekanisk trykspindel.

Tilbehør

Varenr.	Produkt navn
K-600-014	Sæt med udskiftelige trykstykker til KUKKO-trykspindler

Er bestanddel af

Varenr.	Produkt navn
EVLW-2-INDUSTRIE	Salgsvæg industri
WT-1-INDUSTRIE	Aftrækkersortiment - industri
EVLW-INDUSTRIE BASIC	Salgsvæg industri

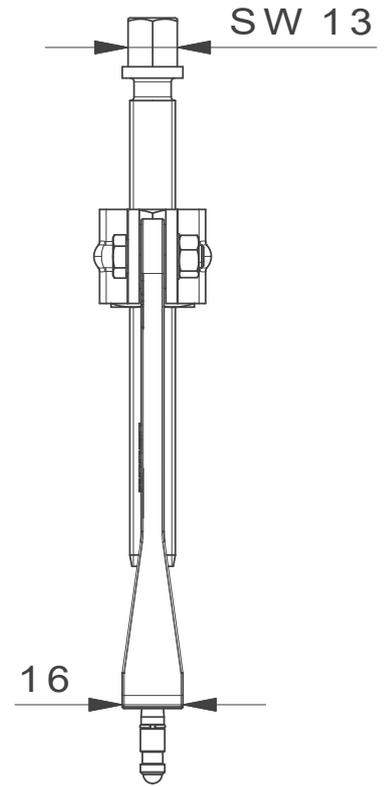
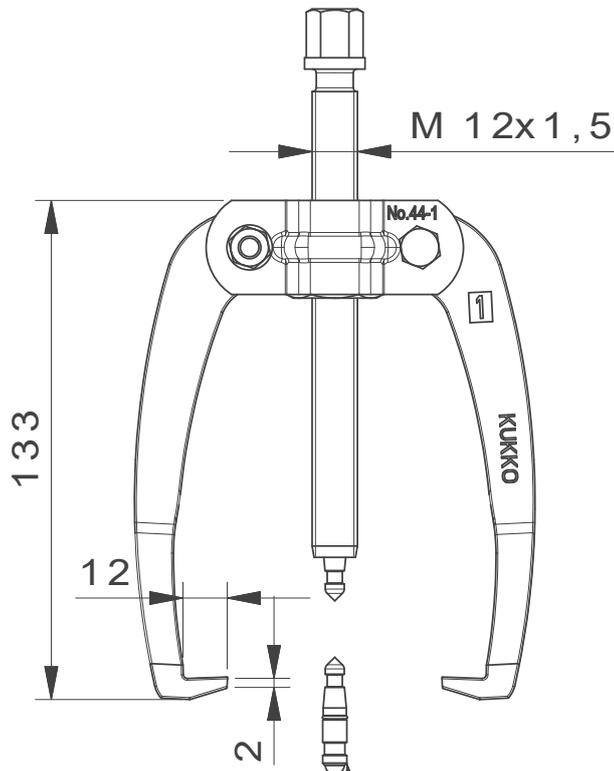

Mit Wechseldruckstück

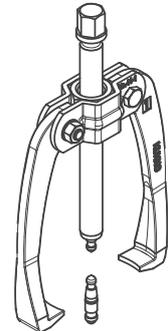
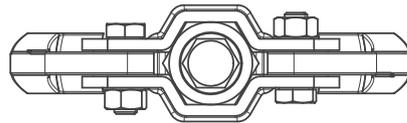

**Kleinbongartz
& Kaiser
oHG**
Werkzeugfabrik
Hilden - Germany

Dokumentname:
44-1_2-armiger Universal Abzieher

Toleranz:
DIN ISO 2768-m

Dokumentbeschreibung:
Baugruppe

Material:
Hoch legierter Werkzeugstahl /
High alloy tool steel

Erstellt von:
Breidenbach

Erstellungsdatum:
02/03/2016

Maßstab:
1:2

Teilbeschreibung:

2-armiger Universal Abzieher/
Universal 2-jaw puller with self-centering jaws

Wärmebehandlung / Härte:
vergüteter Stahl/ tempered steel

Oberflächenbehandlung:

Artikelnummer / ZNR.:
44-1

Dokumentversion:
-

Schutzvermerk
ISO 16016
beachten