

Rubber expansion joint - Type A-2 and A-4

Lateral expansion joint DN 20 – DN 1000



Type A-2



Type A-4

Structure type A-2

Lateral expansion joint consisting of a rubber bellows with rotatable flanges and tie rods (external restraints) to absorb reaction force from internal pressure

Structure type A-4

Lateral expansion joint consisting of a rubber bellows with rotatable flanges and tie rods (external and internal restraints) to absorb reaction force from internal pressure or vacuum

Rubber bellows PN 16

- Highly elastic molded bellows in various rubber grades
- Synthetic fibre reinforcement
- Wire-reinforced self-sealing rubber rim
- Electrical impedance 10^3 to 10^6 Ohm (DIN IEC 93, VDE 0303-30)

Rubber grade*	Colour code	Possible uses
EPDM	orange	Hot water, acids, lyes
NBR	red	Oil
CIIR	white	Drinking water

*Check or inquire about the resistance of the rubber grade to temperature and medium.

Technical design

Max. perm. operating pressure	16 bar*
Max. perm. temperature	+100 °C
Bursting pressure	≥ 48 bar
Vacuum operation	DN 20-50 without vacuum supporting ring, DN 65-1000 with vacuum supporting ring

Max. operating pressure to be set 30 % lower for shock loads.

*Please consider a decrease of pressure due to temperature (see technical annex).

Flanges

Version

- Flanges with stabilizing collar and ears to carry the tie rods
- Flange drilling for through bolts
- Special machined groove for rubber rim

Dimensions

Standard: DN 20 - DN 175 (PN 16)
 DN 200 - DN 1000 (PN 10)
 DN 20 - DN 400 (PN 6)
 according to EN 1092

Others: DIN EN, ANSI, BS etc.

Connection dimensions see technical annex

Materials

Standard: 1.0038 (S235JR)
 Others: 1.4541, 1.4571 etc.

Corrosion protection

Standard: DN 20 – DN 400
 electrogalvanized
 DN 450 – DN 1000
 hot-dip galvanized
 Others: special varnish,
 special coating, etc.

Applications

- for reducing thermal and mechanical tension in pipes and their system components, e.g.
 - pumps
 - compressors
 - motors
- for muffling vibration and noise
- for compensating lateral movement
- to compensate for installation inaccuracies
- to compensate for ground and foundation settlement or tank settlement during filling

Tie rod restraints

- DN 20 - DN 150 Tie rods carried on silencing rubber sockets
- DN 175 - DN 1000 Tie rods carried on spherical washers and conical seats

Materials

Standard: tie rods 8.8

Others: stainless steel

Corrosion protection

Standard: electrogalvanized

Others: hot-dip galvanized

Accessories

- Vacuum supporting ring
- Internal guide sleeve
- Flame-proof protective cover
- Protective hood
- Protective tube

Certificates

- CE (DGR 97/23/EG)
 - Bureau Veritas
 - Det Norske Veritas
 - Drinking water
 - Lloyd's Register of Shipping
 - TÜV (KTA)
- Others see technical annex

Dimensions standard program

DN	BL*	Pressure rate	Ø di Bellows inner Ø	Ø C Raised face outer Ø	Ø E Raised face inner Ø	Ø W Convolution Ø unpressurized	PN Flange connection EN 1092	Ø D Flange outer Ø	b Flange thickness	H Flange height
	mm	bar	mm	mm	mm	mm		mm	mm	mm
20	100	16	22±3	51	30	55	16	115	16	195
25	100	16	22±3	51	30	55	16	115	16	195
32	125	16	31±3	72	39	78	16	140	16	220
32	150	16	31±3	72	39	88	16	140	16	220
40	125	16	39±3	81	45	86	16	150	16	230
40	150	16	39±3	81	45	96	16	150	16	230
50	125	16	49±3	95	56	97	16	165	16	240
50	150	16	49±3	95	56	107	16	165	16	240
65	125	16	65±3	115	72	113	16	185	18	260
65	150	16	65±3	115	72	123	16	185	18	260
80	150	16	77±3	127	84	135	16	200	20	300
100	150	16	100±3	151	109	160	16	220	20	350
125	150	16	127±3	178	133	184	16	250	22	385
150	150	16	153±3	206	161	212	16	285	22	420
175	150	16	176±3	230	185	236	16	315	22	440
200	150	10	202±3	260	209	265	10	340	25	465
200	175	10	202±3	260	209	265	10	340	25	465
250	175	10	252±3	313	262	318	10	395	25	520
250	200	10	252±3	313	262	318	10	395	25	520
300	200	10	303±3	363	312	373	10	445	25	570
350	200	10	344±3	423	360	420	10	505	30	630
400	200	10	396±3	474	410	460	10	565	30	690
450	250	10	435±8	532	450	575	10	615	35	795
500	250	10	485±8	584	500	625	10	670	35	850
600	250	10	585±8	684	600	725	10	780	40	960
700	275	6	690±10	800	700	850	10	895	40	1075
800	275	6	790±10	900	800	950	10	1015	40	1195
900	300	4	890±10	1008	900	1050	10	1115	40	1295
1000	300	4	990±10	1108	1000	1150	10	1230	40	1410

*DN 32 to DN 300 also available in BL 130 mm as type R-2.
From DN 200 higher pressure rate available on request.

Movement compensation

DN	BL	Δ lat Lateral movement ± mm	Permissible vacuum without supporting ring at length BL bar absolute	Weight type A-2 approx. kg
	mm			
20	100	10	-	3.9
25	100	10	-	3.9
32	125	15	0.6	5.1
32	150	20	0.5	5.2
40	125	15	0.6	5.6
40	150	20	0.5	5.7
50	125	15	0.6	6.3
50	150	20	0.5	6.4
65	125	15	0.6	8.0
65	150	20	0.7	8.1
80	150	15	0.65	10.7
100	150	15	0.65	12.6
125	150	15	0.7	16.8
150	150	15	0.75	19.6
175	150	15	0.8	19.9
200	150	15	0.9	22.5
200	175	15	0.9	22.7
250	175	15	0.9	27.5
250	200	15	0.9	27.6
300	200	15	0.9	31.6
350	200	15	0.95	46.7
400	200	15	0.95	57.8
450	250	30	0.35	85.7
500	250	30	0.35	98.0
600	250	30	0.35	133.9
700	275	30	0.5	173.5
800	275	30	0.5	213.6
900	300	30	0.6	250.0
1000	300	30	0.6	295.5

Flange versions

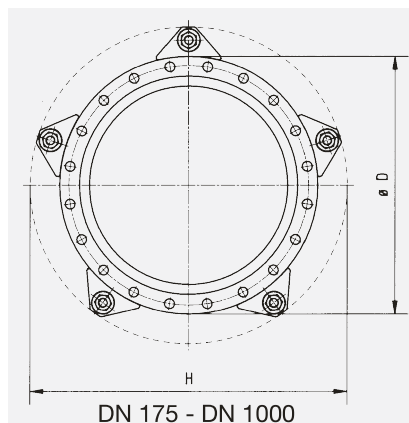
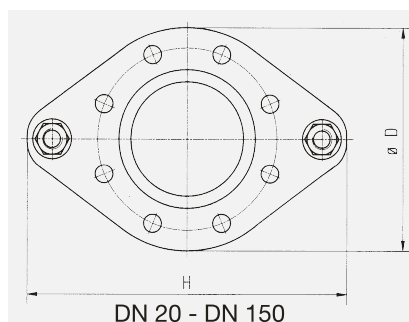

Number of tie rods depending on pressure

Versions

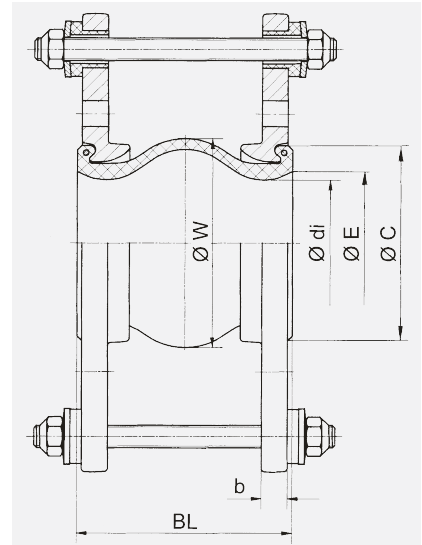

Type A-2

Tie rods, external restraints, carried on silencing rubber sockets

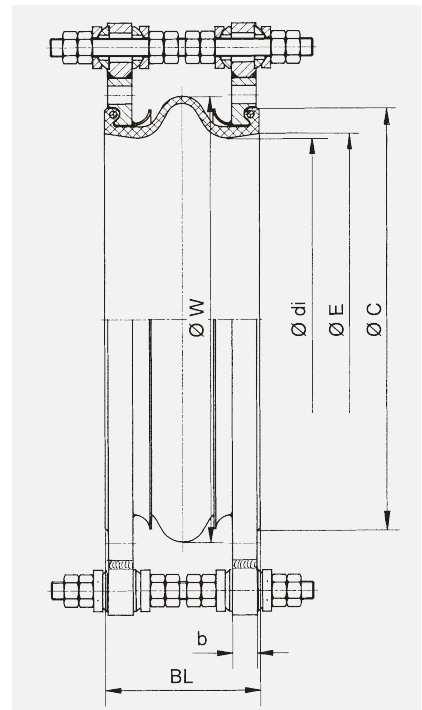

Type A-4

Design as type A-2, additional internal restraints, carried on spherical washers and conical seats

Note

Please comply with the general technical instructions regarding reaction force, moving force, fixed point load, installation instructions etc.

Subject to technical alterations and deviations resulting from the manufacturing process.