

Dealer's Manual

ROAD	MTB	Trekking
City Touring/ Comfort Bike	URBAN SPORT	E-BIKE

Front Chainwheel

GRX

FC-RX810

FC-RX600

Bottom Bracket

BB-RS500

SM-BBR60

BB-RS500-PB

SM-BB72-41B

Contents

Contents	2
IMPORTANT NOTICE	3
TO ENSURE SAFETY	4
List of tools to be used	7
Installation/removal	8
Installing/removing the bottom bracket	8
• Tool combination chart	8
• Installation	9
• Removal	11
Installing/removing the cranks	13
• Installation	13
• Removal	15
Maintenance	16
Replacing the chainring	16
• Single gear types	16
• Double gear types	17



IMPORTANT NOTICE

- **This dealer's manual is intended primarily for use by professional bicycle mechanics.** Users who are not professionally trained for bicycle assembly should not attempt to install the components themselves using the dealer's manuals. If any part of the information on the manual is unclear to you, do not proceed with the installation. Instead, contact your place of purchase or a distributor for assistance.
- Make sure to read all manuals included with the product.
- Do not disassemble or modify the product other than as stated in the information contained in this dealer's manual.
- All manuals and technical documents are accessible online at <https://si.shimano.com>.
- For consumers who do not have easy access to the internet, please contact a SHIMANO distributor or any of the SHIMANO offices to obtain a hardcopy of the User's Manual.
- Please observe the appropriate rules and regulations of the country, state or region in which you conduct your business as a dealer.

For safety, be sure to read this dealer's manual thoroughly before use, and follow it for correct use.

The following instructions must be observed at all times in order to prevent personal injury and physical damage to equipment and surroundings.

The instructions are classified according to the degree of danger or damage which may occur if the product is used incorrectly.

 DANGER	Failure to follow the instructions will result in death or serious injury.
 WARNING	Failure to follow the instructions could result in death or serious injury.
 CAUTION	Failure to follow the instructions could cause personal injury or physical damage to equipment and surroundings.

TO ENSURE SAFETY

WARNING

- **Be sure to follow the instructions provided in the manuals when installing the product.** Only use SHIMANO genuine parts. If a component or replacement part is incorrectly assembled or adjusted, it can lead to component failure and cause the rider to lose control and crash.
-  Wear approved eye protection while performing maintenance tasks such as replacing components.

Be sure to also inform users of the following:

- *Never use alkali based or acid based solvents, such as rust cleaners. If those solvents are used the chain might break and cause serious injury.*
- *Clean the chain with an appropriate chain cleaner regularly. Intervals between maintenance depend on the use and riding circumstances.*
- Check that there are no cracks in the crank arms before riding the bicycle. If there are any cracks, the crank arm may break and you may fall off the bicycle.
- Be careful not to let the hemming of your clothes get caught in the chain while riding. Otherwise, you may fall off the bicycle.
- Check the chain for any damage (deformation or cracking), skipping, or other abnormalities such as unintended gear shifting. If any problems are found, consult your place of purchase or a distributor. The chain may break, and you may fall.

For installation to the bicycle, and maintenance:



- Install the inner cover correctly. If it is not installed correctly, the axle may rust and become damaged, and the bicycle may fall over and serious injury may occur as a result.
- Be sure to use a torque wrench with the specified torque value when tightening the crank mounting screws, and re-check the tightening after riding approximately 100 km. If riding when the tightening torque is weak, the crank could detach and you may fall off the bicycle.
- Re-checking the tightening torque of the crank is necessary when the crank is subjected to strong blows from a fall. If riding when the tightening torque is weak due to a strong blow, the crank could detach and you may fall off the bicycle.

⚠ CAUTION**Be sure to also inform users of the following:**

- Be careful not to touch the teeth of chainrings. There is a danger of injury.

NOTICE**Be sure to also inform users of the following:**

- Be sure to keep turning the crank arm during the shifting lever operation.
- When the chain is in any of the positions shown in the figures, the chain may come into contact with the chainring or front derailleur and generate noise. If noise is a problem, shift the chain onto the next largest sprocket or the one after it.

	Double
Chainring	
Sprocket	

- Check that there is no excess play or looseness in any fastening sections before riding the bicycle. Also, be sure to retighten the crank arms and pedals at periodic intervals.
- Use a neutral detergent to clean the crank arm and the bottom bracket. Using alkaline or acidic detergents may cause discoloration.
- If you notice an abnormal noise or other abnormality during pedaling, contact your place of purchase.
- Do not wash the bottom bracket with high-pressure washer. Water may enter the bearing section and cause noise or adhesion.
- If you feel any excess play in the bearing section, the bottom bracket should be replaced.
- The gears should be periodically washed with a neutral detergent. In addition, cleaning the chain with neutral detergent and lubricating it can be an effective way of extending the life of the gears and the chain.
- The cuffs of your clothing may get dirty from the chain while riding.
- This product is not warranted against damage caused by improper use, abuse, or issues resulting from a crash, unless the circumstance was caused by a manufacturing defect.

- Products are not guaranteed against natural wear and deterioration from normal use and aging.
- For maximum performance we highly recommend SHIMANO lubricants and maintenance products.

For installation to the bicycle, and maintenance:

- When installing the pedals, apply a small amount of grease to the threads to prevent the pedals from sticking. Use a torque wrench to securely tighten the pedals. (tightening torque: 35 - 55 N·m). The right crank has a right-hand thread, and the left crank has a left-hand thread.
- If the bottom bracket shell is not parallel, gear shifting performance will drop.
- If the chain keeps skipping during use, consult the place of purchase.
- When installing the left and right adapters, apply grease and be sure to install the inner cover. Otherwise, the waterproofing performance will worsen.
- To ensure the best performance, be sure to use only the specified type of chain.

Front chainwheel	Recommended chain
FC-RX810	CN-HG701-11
FC-RX600-11	CN-HG601-11
FC-RX600-10	CN-HG54

- If a squeaking noise is heard coming from the bottom bracket axle and the left crank arm connector, apply grease to the fastening section, then tighten it to the specified torque.
- Only use chainring combinations listed below. If other chainring combinations are used, it can create poor shifting and cause the chain to jam, resulting in damage to the bicycle.







FC-RX810		Top
		48T-ND
Low	31T-ND	X

FC-RX600		Top
		46T-NF
Low	30T-NF	X



The actual product may differ from the illustration because this manual is intended mainly to explain the procedures for using the product.

List of tools to be used





The following tools are needed for installation, adjustment, and maintenance purposes.

Tool			
	5 mm hexagon wrench		Soft face mallet
	8 mm hexagon wrench		Hexalobular [#30]
	17 mm spanner		TL-FC16 / TL-FC18



BB-RS500

Tool			
	TL-FC32		TL-FC36
	TL-FC33		

SM-BBR60

Tool			
	TL-FC25 & TL-FC32		TL-FC25 & TL-FC36
	TL-FC25 & TL-FC33		TL-FC37

SM-RS500-PB/SM-BB72-41B

Tool			
	TL-BB12		TL-BB13



Installation/removal

Installing/removing the bottom bracket

Tool combination chart

The tools required for installing and removing the bottom bracket differ by model. Combine and use any of the tools specified in the table.

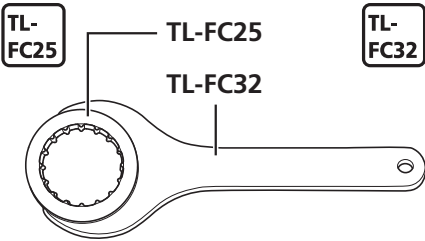
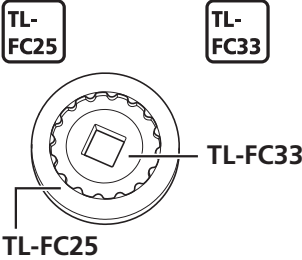
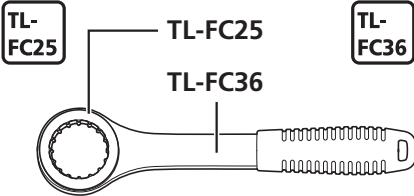
SM-BBR60

TL-FC25 & TL-FC32	TL-FC25 & TL-FC33
	
TL-FC25 & TL-FC36	TL-FC37
	

NOTICE

- When using TL-FC25 & TL-FC33, an impact wrench cannot be used.

BB-RS500

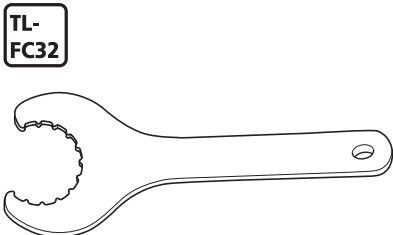
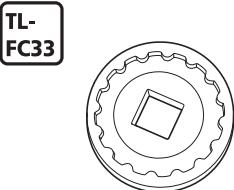
TL-FC32	TL-FC33
	

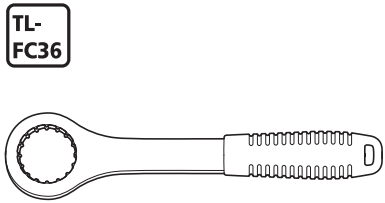
TL-FC36	TL-FC36
	

Installation

▶ Threaded bottom bracket

1. Install the inner cover, adapter, and spacer.

- (1) Apply grease to the left and right adapters.
- (2) Use the SHIMANO original tools (refer to "Tool combination chart" in "Installing/removing the bottom bracket") to tighten the left and right adapters.

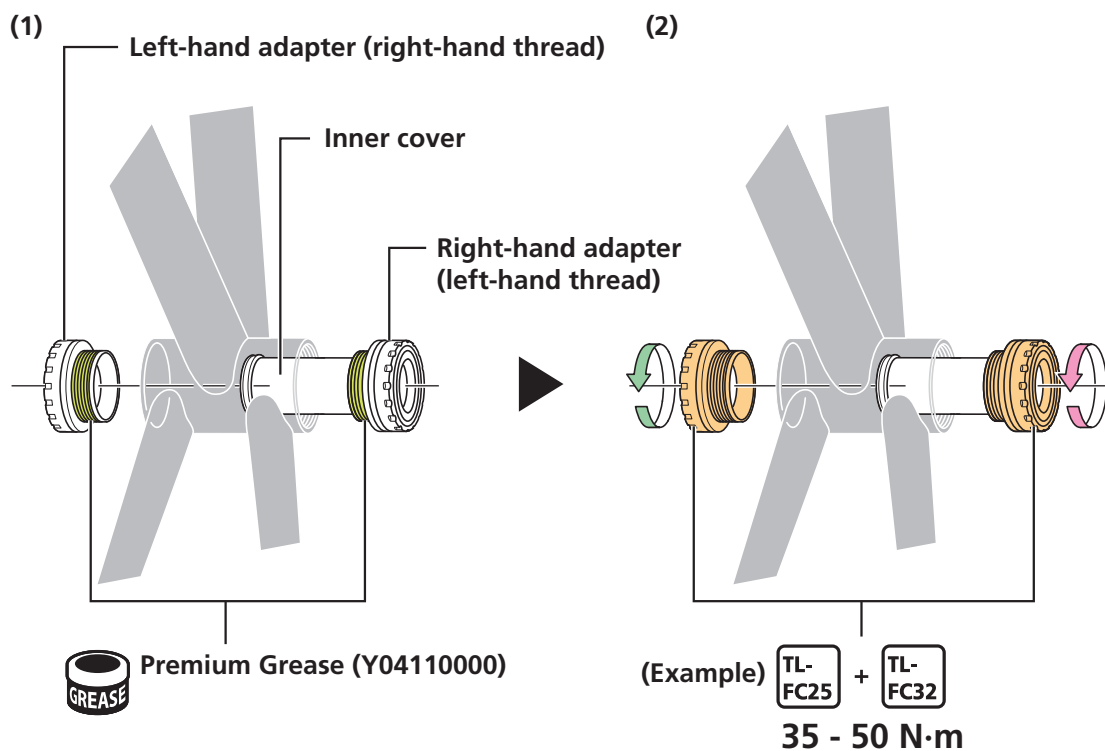

NOTICE

- If it is a 70 mm [M36] bottom bracket, turn the right-hand adapter clockwise (right-hand thread).

▶ Press-fit bottom bracket

1. Set the bottom bracket in the bottom bracket shell.

- Use a bottom bracket compatible with a shell width of 86.5 mm.
- Set the inner cover and adapters.

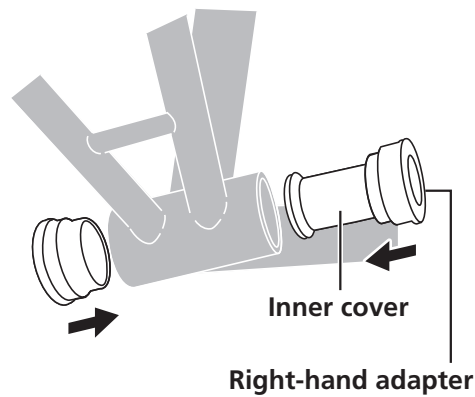
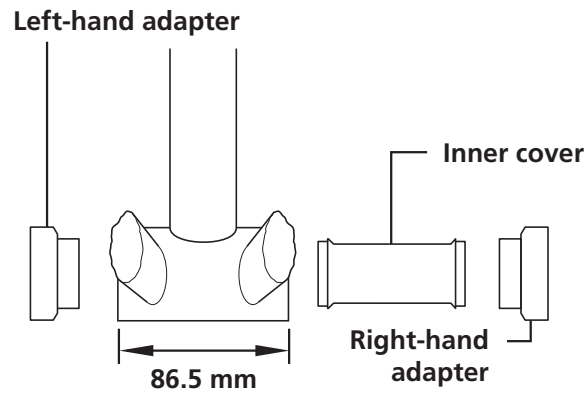

NOTICE

- If the frame has openings for the bottom bracket shell, attach an inner cover to prevent foreign objects from getting inside. If there are no openings, it can be installed without an inner cover.

2. Insert the SHIMANO original tool into the bottom bracket.

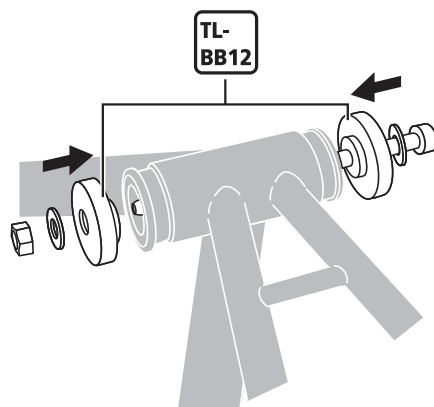

3. Use a spanner to press-fit the bottom bracket.

Make sure that the contact surface of the bottom bracket is parallel with the contact surface of the bottom bracket shell.

* Press-fit until there is no more gap between the bottom bracket and the bottom bracket shell.

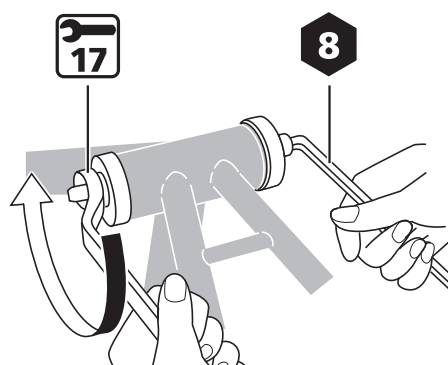

Removal

▶ Threaded bottom bracket

1. Perform the removal in the reverse order from "Installation" in "Installing/removing the bottom bracket."

▶ Press-fit bottom bracket

1. Insert the SHIMANO original tool into the bottom bracket.

- (1) Extend the flaps to taper the tip of the SHIMANO original tool.
- (2) Insert the SHIMANO original tool from the opposite side of the adapter you wish to remove.
- (3) As shown in the figure, press down on the protruding portion of the tip with your hand to expand the flaps.

- (4) Push the tool in further while continuing to press down on the tip, until the flanges on the flaps engage with the adapter.

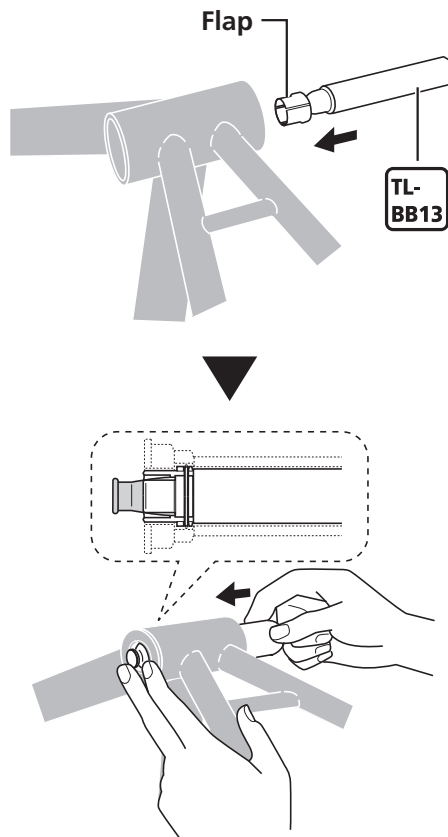

- 2.** Tap the SHIMANO original tool with a soft face mallet to push out the adapter.

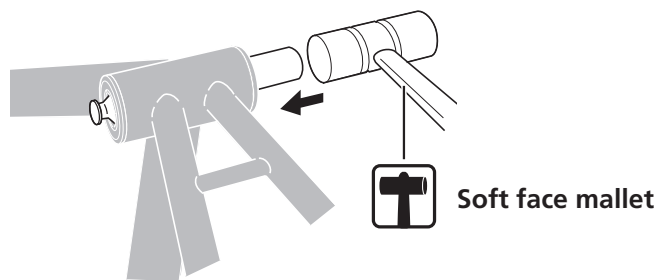

- 3.** Remove the adapter on the opposite side in a similar manner.

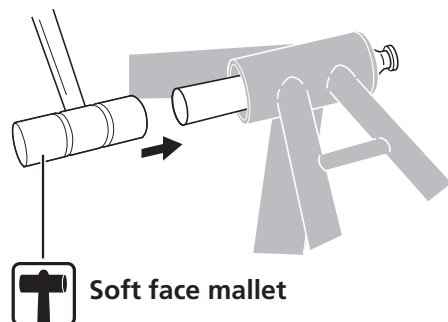

NOTICE

- Do not reuse the adapters as they can be damaged during removal.

Installing/removing the cranks

Installation

1. Insert the right crank arm unit into the bottom bracket.

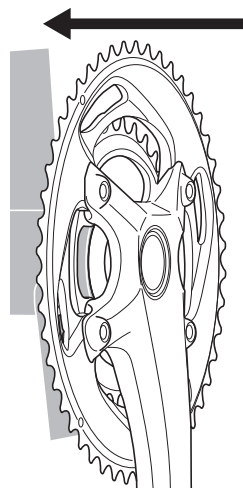

2. Set the left crank arm onto the axle of the right crank arm.

- (1) Apply grease to the axle of the right crank arm unit.
- (2) Align the wide part of the left crank arm spline with the wide part of the spline on the crank axle.

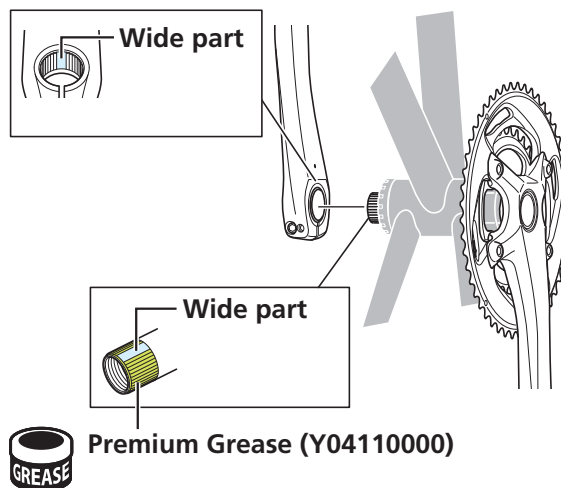

3. Install the cap.

- (1) Apply grease to the cap as specified in the figure.
- (2) Tighten using the SHIMANO original tool.

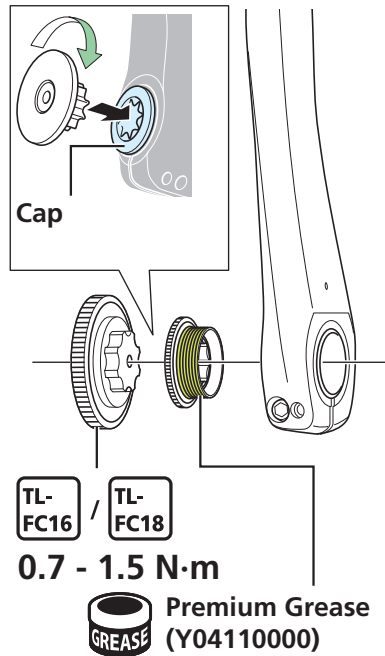

4. Tighten the mounting screws to secure the crank arm.

- (1) Set the stopper plate in the direction shown in the figure and push it in.
- (2) Check that the plate pin is securely inserted.

- (3) Tighten the left crank arm screws alternately until the 2 screws reach the specified torque.

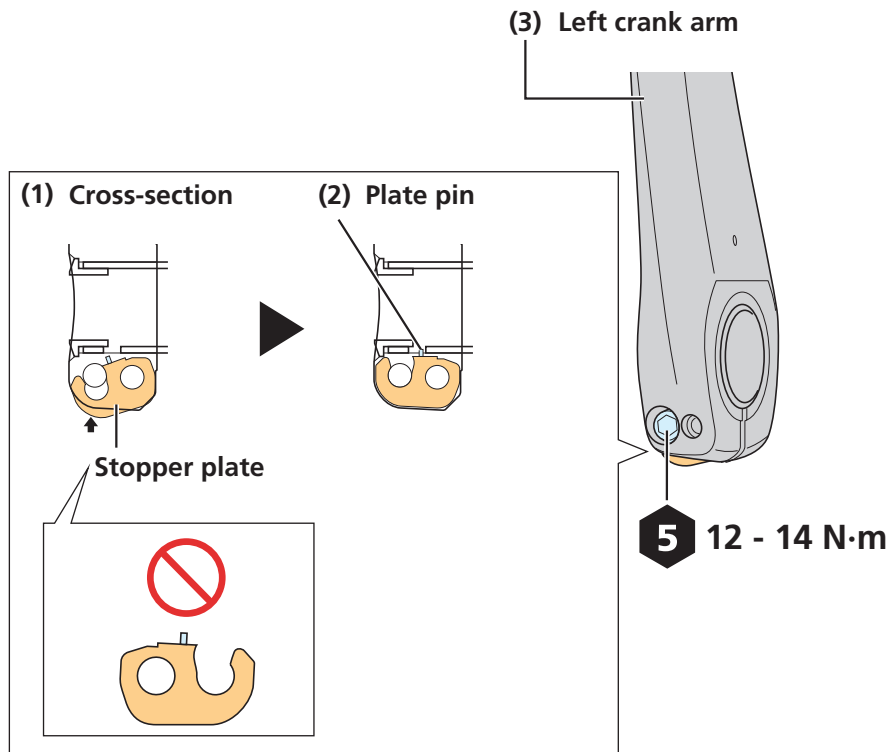

Removal

1. Perform the removal in the reverse order from "Installation" in "Installing/removing the cranks."

Maintenance

Replacing the chainring

NOTICE

- Gear shifting performance will be reduced if the installation positions of the chainrings are incorrect. Be sure to install the chainrings in the correct positions.
- Make sure to use the correct combination of SHIMANO genuine parts, otherwise the cranks or chainrings may become damaged.

Single gear types

1. Remove the chainring from the crank arm.

2. Set the chainring on the crank arm.

With the marked side facing outward, set the chainring so that the convex section is positioned under the crank arm.

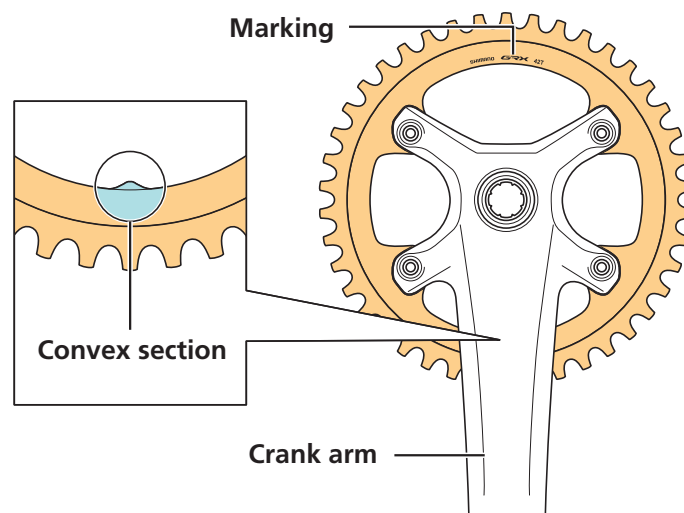

3. Secure the chainring.

Tighten the chainring fixing screws.

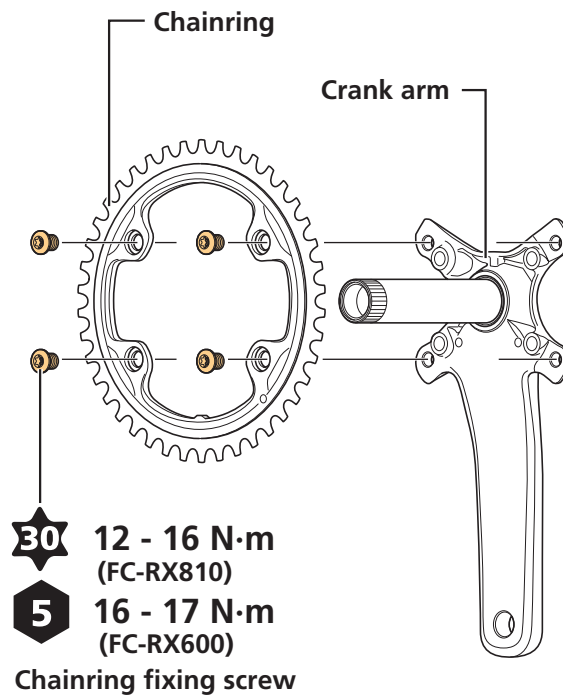

Double gear types

1. Remove the chainring from the crank arm.
2. Install the largest chainring on the crank arm.

(1) With the marked side facing outward, set the largest chainring so that the chain drop prevention pin is positioned under the crank arm.

(2) Tighten the chainring fixing screws.

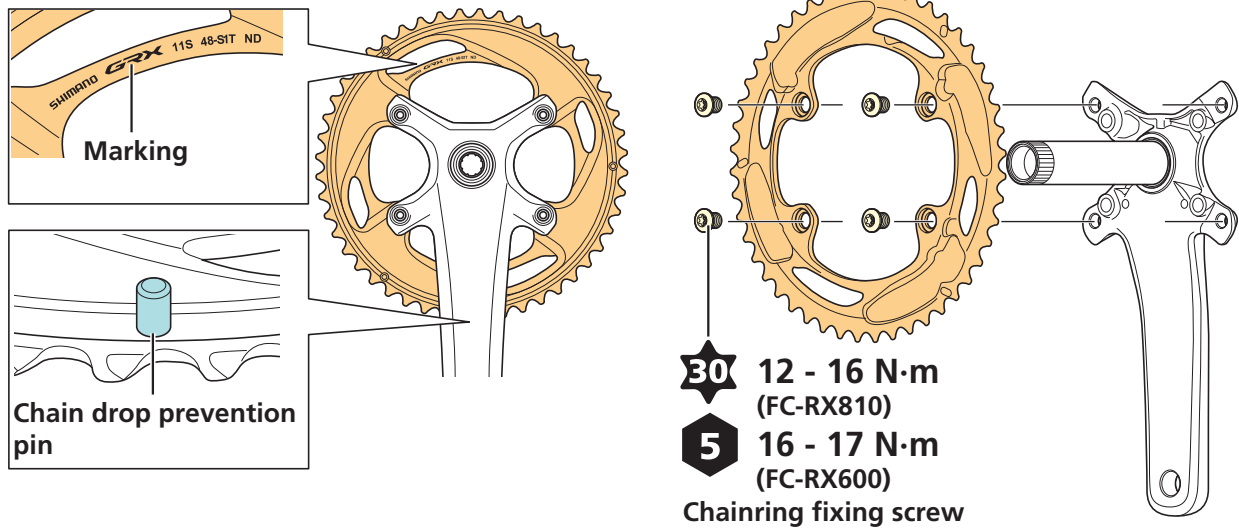

3. Install the smallest chainring.

(1) With the marked side facing inward, set the smallest chainring so that the convex section is positioned under the crank arm.

(2) Tighten the chainring fixing screws.

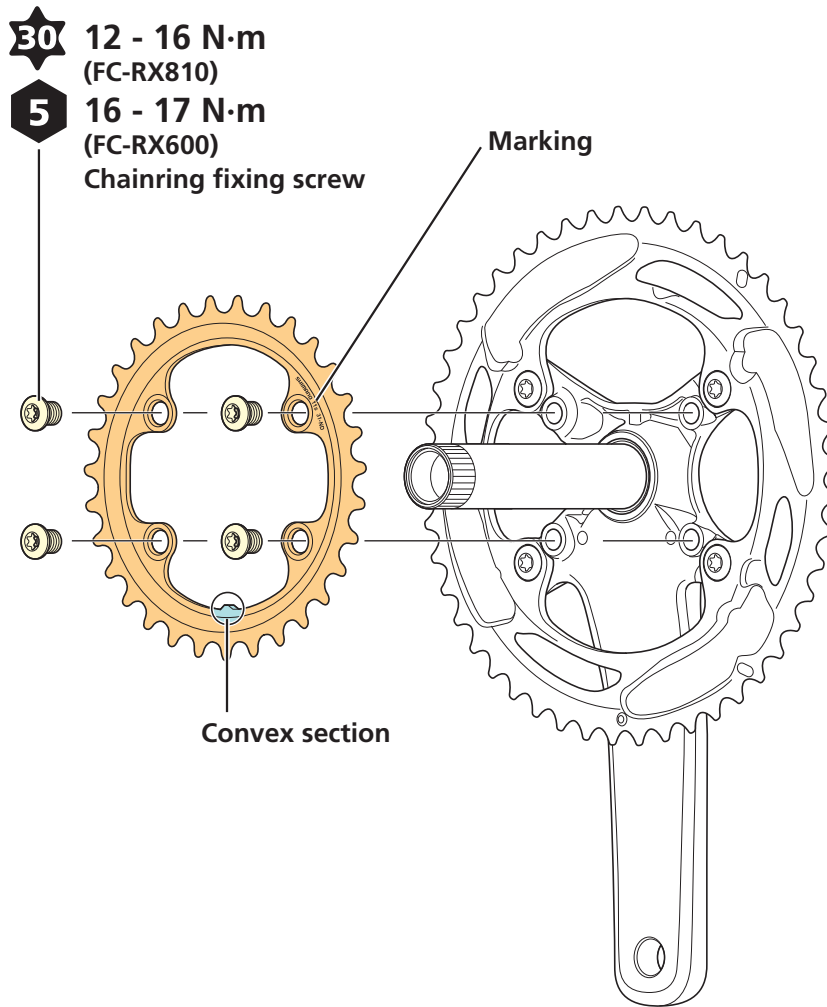

SHIMANO

SHIMANO NORTH AMERICA BICYCLE, INC.

One Holland, Irvine, California 92618, U.S.A. Phone: +1-949-951-5003

SHIMANO EUROPE B.V.

High Tech Campus 92, 5656 AG Eindhoven, The Netherlands Phone: +31-402-612222

SHIMANO INC.

3-77 Oimatsu-cho, Sakai-ku, Sakai City, Osaka 590-8577, Japan

Please note: specifications are subject to change for improvement without notice. (English)

© Nov. 2020 by SHIMANO INC. ITP